

VOLVO EXCAVATOR

EW140B



VOLVO

A small machine with big resources

When you need a compact machine with lots of power, then the EW140B is the perfect excavator. It is small and manoeuvrable enough to work in tight spaces, robust and powerful enough to handle heavy jobs. Due to the compact design and ease of operation, the machine's effectiveness in narrow streets and on urban sites is unbeatable. The EW140B is a complete machine that's perfect for any job - both on and off the road.



Tradition and innovation in perfect harmony

The new generation of Volvo wheeled excavators is a logical development of earlier models. At the same time, the EW140B is a whole new machine, where well-proven design solutions and new technology meet. Perfect harmony between tradition and innovation has resulted in an excavator that stands in a class of its own. During development of the EW140B, we looked at every component in our excavators to see how we could maximize comfort, reliability, productivity and service availability. In order to reach these targets, we focused on a few key areas. The results include a new Volvo-designed engine that's reliable and powerful, built to perfectly match hydraulic output levels for maximum productivity. An improved operator's cab with higher safety and

comfort, giving the operator the easiest and safest workday possible. In addition, all of the machine's parts have been developed for easier daily maintenance, increasing time for productive work.

At your service

In this brochure, you can take a look at all the new innovative features on the EW140B. And keep in mind that every Volvo excavator is backed by complete customer support from Volvo's global network of dealers and organizations for service and spare parts.

Specifications EW140B

● Engine:	Volvo D5D EBE2	● Breakout force:	89,5 kN	● Max digging depth:	5,7 m
Rated power at:	31,7 r/s (1900 r/min)	● Bucket capacity:	0,19-0,75 m ³	● Max. travel speed:	30 km/h
SAE J1995, gross:	92 kW (123 hp)	● Max digging reach:	9,3 m	● Operating weight:	14,3-15,7 t
ISO 9249, DIN 6271, net:	88 kW (118 hp)				



Superior performance



We've designed an engine with optimal productivity

One of the greatest differences on the new excavators are the new Volvo in-house produced four cylinder low-emission engines. Using vast experience and well-proven technology, we've designed an engine with optimal productivity that goes beyond all known environmental requirements, with less sound and lower fuel consumption than the predecessors. Our engines use fuel extremely efficiently, and this means minimized hazardous emissions without any power loss. Since the engines are matched to the hydraulics, it's possible to operate at low engine speeds and still maintain quick movement of the digging equipment.

Engine

- New turbocharged air-to-air intercooled four cylinder low emission Volvo engine built specifically for use in Volvo excavators easily meets EU STEP2 requirements.
- The electronically controlled fuel injection provides quick response, lower fuel consumption and faster work-cycles.
- High engine output gives top class performance.
- Auto idling system reduces noise and fuel consumption.

The combination of the new Volvo engine, the advanced hydraulics and the excellent digging geometry makes the new EW140B perfect for a wide variety of applications. It is a complete excavator that is just as good at lifting and travelling as it is at digging. Excellent off-road mobility and on-road capacity allow you to maintain higher average speed, enabling fast transport between different work sites.

Excellent manoeuvrability, even at low engine speeds

Volvo's advanced hydraulic system has been refined for the new generation's excavators, making the new machines extremely smooth and manoeuvrable. The hydraulics pump oil to the functions only when it's needed, and all power is concentrated to the activated function. The operator has complete control of the machine and attachment, giving a feeling of being one with the machine.

The system is designed and built using proven and highly reliable components – optimised for Volvo – enabling simultaneous activation of several movements and giving the operator safe control of both load and attachment. This provides excellent manoeuvrability, even at low engine speeds. We dare say that it's the best hydraulic system on the market. With Volvo's unique float mode, production increases while reducing fuel consumption and wear.

Hydraulics

- State-of-the-art hydraulic system gives you excellent manoeuvrability with minimal power losses.
- One-touch power boost for increase in digging and lifting forces.
- Durable aluminium core oil-cooler with an electronically controlled hydrostatic fan is located separately from radiator for easy access to clean.
- High versatility for extra hydraulic equipment.

High average speed guarantees high productivity

The excavators feature world class digging and lifting forces. An engine with high torque drives the hydraulic system, delivering both high working pressure and high flow. High forces and quick movements combined with outstanding manoeuvrability guarantee high productivity.

Just as good at lifting high as it is at digging deep

With three different digging booms, a wide range of dipper arm lengths and attachments, there's a solution to all needs. Rugged booms and dipper arms are dimensioned for the most extreme stresses. And, with Volvo's tried-and-tested hydraulic quick-fit, you can change attachments without leaving the cab. Unbeatable flexibility that generates productivity. The unique boom geometry also delivers higher lift and very good dumping height, and that means faster work cycles. These new excavators are just as good at lifting high as they are at digging really deep.

- Optional boom float position – featured by Volvo since 1968.

Digging equipment

- Booms and dipper arms built to withstand extreme stress and provide long, reliable lifetime.
- Excellent digging and lifting capacities.
- A wide selection of booms and dipper arms gives you a solution for every need.



Complete control

Technical solutions must always be introduced on human terms. It's the operator who should be in command of the machine, not the opposite. That's why our new excavators are equipped with new advanced technology that always gives the operator complete control. Volvo's mode selector allows the operator to select working mode so that the machine adapts to the current operating techniques and operating conditions. The new instrument panel combined with MDU - Machine Display Unit - provides the operator with all relevant information about machine status in a simple and logical manner.

Make your own mode pre-setting

The customer mode, allows machine performance to be set to the operator's own operating conditions and operating technique. In a very simple way, the hydraulic oil flow and engine speed can be set individually.

The new instrument panel combined with MDU - Machine Display Unit - provides the operator with all relevant information about machine status in a simple and logical manner. This allows the operator to concentrate on the job. Coolant temperature and fuel level are highly visible at a glance, and it's just as easy to get information on engine speed and the selected mode, as well as engine hours and system voltage. Warning lights and an audible alarm signal alert the operator in case of a malfunction.

Go as slow as you desire

The Power Shift transmission allows the operator to shift between low and high speed range on the move. The drive train has three separate max. speeds, of which one is a 3 km/h creep speed. However, sometimes road con-

struction and grading jobs require even slower speeds. That's why the function is now adjustable, the operator can go as slow as desired, depending on the job that needs to be done.

A truly stable performer

The outriggers and the dozer blade give the already rugged and well-balanced machine extra stability. The outriggers spread is almost four metres. Still, the outriggers are no problem in off-road operations, they simply fold in close to the machine. The dozer blade makes the machine a truly stable performer. Sometimes, the machine operates in inaccessible areas and rough ground conditions that require high flexibility and all-round capability. With Volvo's excavators, you can choose to run all supports simultaneously or with separate movements, in any combination. In some situations, it might be impossible to use the outriggers. That's why it's possible to select drum brakes as an option, ensuring stable digging without play in the axles, even without outriggers.



Electrical / Electronic system

- New instrument panel, combined with Machine Display Unit (MDU) enables even faster operating status checks and greater work efficiencies.
- New mode selector switch with customer mode setting for the preferred machine performance.

- Well protected and easily accessible distribution box for fuses and relays.

Undercarriage

- High travel speed and tractive force with good ground clearance enabling excellent on-road and off-road mobility.

- Rugged design of the outriggers and the dozer blade - wide outrigger spread.

- Independently or simultaneously operated undercarriage supports.



More compact on the outside, more spacious on the inside

Function is a part of every detail in the new machine. The EW140B is made compact, for easier operation and more efficient work in urban environments and narrow streets. Excellent boom lifting height and short tail radius makes it possible to slew the machine around even in very tight areas. The cab is slightly more square than before, making it more spacious on the inside. There's lots of room for your feet as well as a practical lunchbox compartment and ample space for any personal items you may want on long shifts.



A good work environment is not an option

During development of the new machines, we've worked hard to make the cab as operator-friendly as possible. There's good reason for that; a good work environment is not an option when caring for operator comfort and operating pleasure. And only a comfortable operator does a good job. The cab is equipped with a new ergonomic operator's seat, with multiple adjust-

ment functions for optimal individual comfort. Even the cab's lever consoles have vertical adjustment. The electronic climate control system always ensures a comfortable cab environment. In short, the new machine offers a safe and comfortable workplace to be enjoyed, even during those long shifts.

A cab with a view

Good comfort and high safety require good visibility all around the machine in all weather and operating conditions. Visibility in the new cab has been improved. The strong yet narrow cab pillars give the operator a safe workplace, significant reduction of 'blind spots' on both sides and excellent forward visibility on the work site. Just like before, the front windshields of tinted safety glass are designed without mouldings, giving a clear view in the digging direction without blinding glare from intense sunlight.

Perfect co-ordination between operator and machine

Even the smallest parts in the EW140B are designed for perfect co-ordination between operator and machine, making

work effective and comfortable at the same time. The operator should have a comfortable operating environment, and it should be possible to really use all of the machine's functions and features. The machine responds immediately to the operator's commands, pedals and levers react consequently and distinctly to every movement. Instruments are easy to read and controls are within easy reach, ergonomically and logically placed to make work as operator-friendly and smooth as possible. You, the operator, have full control of both machine and attachment in all jobs, even the toughest applications, making it possible for you to work long effective shifts without getting tired.

Cab

- Ergonomically-designed cab provides greater operator comfort for higher operator efficiency and productivity.
- Improved visibility for safer and more efficient operation.
- Increased cooling and heating capacity, with Electronic Climate Control (ECC) and thirteen air vents.

- Very low cab noise level.
- Supported by gas springs, the upper front pane is very easy to slide up.
- High quality comfortable seat with nine different adjustments.

Superstructure

- Compact tail slew radius and low machine profile.
- Large side rear view mirror enhancing visibility and safety for both driving and working.



Care – down to the last detail

Volvo wheeled excavators are designed and built using the most advanced systems and technology available in the world today. Nothing has been left to chance. But, technology has not been allowed to stand above all. Instead, we've focused on operating safety and care - care of the machine, the environment and, most of all, the operator.

Easiest and safest workday possible

A wide range of ergonomic details and ingenious solutions, along with longitudinal mounting of the engine in the machine, mean easy service and routine maintenance from ground level. For service points higher up, the machine has the market's widest and safest platforms with anti-slip steps. Behind the cab on the middle of the machine, there is a spacious platform with lots of room to work. All these features encourage and facilitate the important service work, and give the operator the easiest and safest workday possible.

When it comes to safety, Volvo is in a class of its own

When it comes to operator safety and machine safety, Volvo is in a class of its own. An excavator must be able to handle tough work and withstand high stresses. It's important that travelling is safe, and this is something we've worked hard on for the new generation of excavators. The highly visible hydraulic safety bar in front of the left control console enables the operator to easily enter or leave the machine with-

out activating any machine functions. Volvo excavators feature a unique travel lock. By turning a switch, you lock the entire superstructure to the undercarriage and, at the same time, all hydraulic functions are blocked. This prevents accidental movement of the digging equipment, slew or the undercarriage's support functions when travelling on a public road. In addition, the oscillating axle is automatically locked by using the digging brake, ensuring full stability at work. It can also be locked manually.

Automatic speed retardation gives you peace of mind

When travelling downhill, the safety feature retards the machine speed and prevents it from overspeeding. This enables less use of the service brake and gives the operator great peace of mind and safety. Should the machine run out of diesel fuel, there's an emergency system that always allows steering and braking. With the installed accumulators, the brakes in the new machines always provide reliable braking.



Serviceability

- On-ground maintenance of engine.
- Spacious service walkway with self-cleaning anti-slip steps.
- Large, easy-to-open doors and hoods with locks.
- Centralised and on-ground lubrication for digging equipment and slew bearing.
- Centralised hydraulic pressure check points.

Environment & Safety

- Low emission engines, meeting EU Step 2 emissions standard.
- Low noise hydraulic pumps and hydraulic driven oil cooler fan.
- Optional bio-degradable hydraulic oil.
- Highly visible hydraulic safety lock with tilting console box.

- Safe and easy superstructure alignment to undercarriage for travelling.
- Automatic front axle lock on applying the digging brake.
- Automatic retardation of downhill speed.
- Optional front window safety net, FOPS and FOG.



The EW140B in detail

Engine

The engine is a low emission, turbocharged air-to-air cooling, 4-stroke diesel engine with water cooling, electronically controlled direct injection, that meets EU Step 2 requirements. The engine has been developed especially for excavator use, providing good fuel economy, low noise levels and a long service life.

Air Filter: 2-stage

Automatic Idling System: Reduces engine speed to idle when the levers and pedals are not activated resulting in less fuel consumption and low cab noise level.

Engine.....	Volvo D5D EBE2
Rated power at.....	31,7 r/s (1900 r/min)
SAE J1995, gross.....	92 kW (123 hp)
ISO 9249, DIN 6271, net.....	88 kW (118 hp)
Max. torque.....	555 N.m at 1 400 rpm
No. of cylinders.....	4
Displacement, total.....	4,8 l
Bore.....	108 mm
Stroke.....	130 mm

Electrical system

Contronics, provides advanced monitoring of machine function and important diagnostic information. High capacity and well protected electrical system. Centrally located fuse and relay box using clearly arranged printed circuit board mounted, for easy access, behind the cab. Center passage prepared for connecting optional equipment. A master switch is standard.

Voltage.....	24 V
Battery.....	2 x 12 V
Battery capacity.....	140 Ah
Alternator.....	28 V / 80 A

Cab

The operator's cab has easy access via a wide door opening. The cab is supported on hydraulic dampening mounts to reduce shock and vibration levels. These along with a sound absorbing lining provide low noise levels. The cab has excellent all-round visibility. The front windshield can easily slide up into the ceiling, and the lower front glass can be removed and stored in the door.

Integrated air conditioning and heating system:

The pressurized and filtered cab air is supplied by an automatically controlled fan. The air is distributed via 13 vents.

Ergonomic operator's seat: The adjustable seat and joystick consoles move independently to accommodate the operator. The seat has nine different adjustments and a seat belt to meet any operator's comfort and safety.

Sound Level:

Sound level in cab	
according to ISO 6396.....	73 LpA dB(A)
External sound level	
according to ISO 6395.....	101 LwA dB(A)
(Directive 2000/14/EC)	

Undercarriage

Drive train: One big variable axial-piston motor on the two-step Power Shift gearbox gives power to front and rear axles, both with hub reductions.

Framework: All-welded robust torsion box frame.

Wheels: Alternative single and twin wheels available.

Front axle: Robust excavator axle with automatic or operator controlled front axle oscillation lock. Oscillating $\pm 9^\circ$ (with mudguards $\pm 7^\circ$).

Twin wheels.....	10.00–20
Max. tractive force (net).....	82 kN
Travel speed, on road.....	20,0/30,0 km/h
Travel speed, off road.....	5,3/7,8 km/h
Travel speed, creep.....	3,1 km/h
Min. turning radius.....	6,9 m

Brakes

Service brakes: servo-hydraulically manoeuvred self-adjusting wet multidiscs in two separate brake circuits.

Parking brake: negative wet disc in gear housing, spring applied and pressure released.

Digging brake: service brake with mechanical lock system.

Security system: The 2-circuit travel brakes are supplied with two accumulators in the event of failure in the service brake system.

Weights

Machine with 4,5 m monoblock boom, 2,45 m dipper arm, quickfit S6, 420 kg / 580 l bucket.

* Machine with 4,7 m 2-piece boom.

Total machine weight incl. front dozer blade and rear outriggers..... 15 400 kg*15 650 kg

Total machine weight incl. rear dozer blade..... 14 300 kg*14 550 kg

Service refill capacities

Fuel tank.....	250 l
Hydraulic system, total.....	235 l
Hydraulic tank.....	120 l
Engine oil.....	15 l
Engine coolant.....	21,5 l
Transmission.....	3,4 l
Axle housing	
Front axle.....	8,5 l
Rear axle.....	11,0 l
Final drive	
Wet disc type.....	1,0 l
Drum type.....	1,0 l

Hydraulic system

Closed-centre load sensing hydraulic system with pressure compensated valves. Load independence of movements and flow sharing feature, combined with a high flow electronically controlled pump (power regulation). The system gives superior manoeuvrability and fast movements, for optimal working result and economy.

The following working modes are included in the system:

Parking mode (P):

Parking position for optimal safety.

Travel mode (T):

Engine speed is controlled by travel pedal stroke for low fuel consumption and noise. Work equipment is not able to be operated in this mode for optimal safety.

Working mode (W):

Full working flow with adjustable engine rpm for normal working and best speed utilisation.

Customer mode (C):

Operator can set proper oil flow in accordance with job conditions.

Power Boost:

All digging and lifting forces are increased.

Hydraulic pumps:

Main pump

Type.....low noise axial piston pump

Max. flow.....230 l/min

Brake + steering pump

Type.....low noise gear pump

Max. flow.....32 l/min

Hydraulic oil cooling fan + pilot pump

Type.....low noise gear pump

Max. flow.....46 l/min

Maximum pressures

Implements.....32/36 MPa

Travel system.....36 MPa

Pilot system.....3,5 MPa

Slew system

The superstructure is slewed by the means of a high displacement radial piston motor without reduction gear.

Automatic slew holding brake and anti-rebound valve are standard.

Max slew speed.....10,0 rpm

Specifications

Dimensions

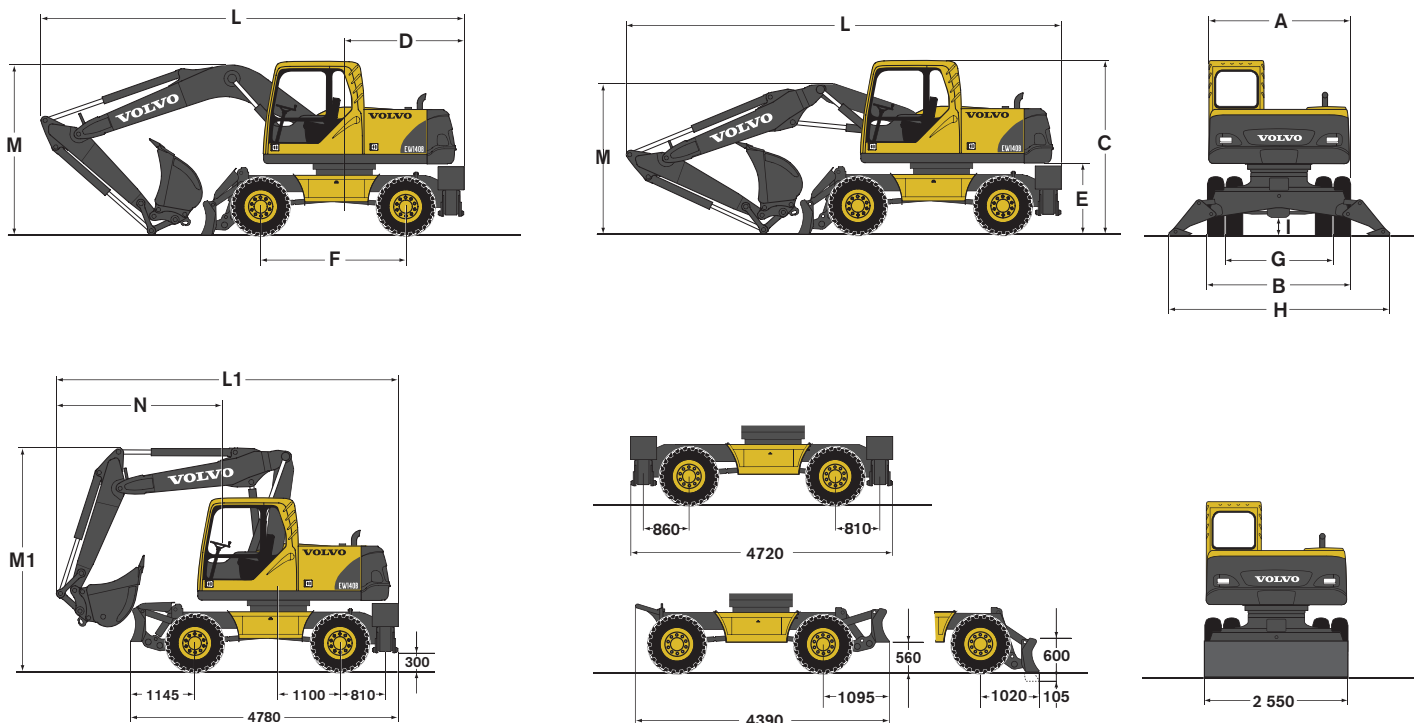

Description	Unit	Monoblock boom				2-piece boom			
		4,5 m				4,7 m			
A. Overall width of superstructure	mm	2 500				2 500			
B. Overall width	mm	2 540				2 540			
C. Overall height of cab	mm	3 110				3 110			
D. Tail slew radius	mm	2 000				2 000			
E. Counterweight clearance	mm	1 270				1 270			
F. Wheel base	mm	2 600				2 600			
G. Wheel gauge	mm	1 915				1 915			
H. Outrigger width, down (front or rear)	mm	3 920				3 920			
I. Min. ground clearance	mm	325				325			
Dipper arm length:		2,0 m	2,45 m	3,1 m	3,0 m**	2,0 m	2,45 m	3,1 m	3,0 m**
L. Overall length	mm	7 630	7 500	7 570*	7 665*	7 820	7 770	7 800*	7 735*
M. Overall height of boom	mm	3 035	3 370	3 370*	3 340*	2 755	3 090	3 110*	3 225*
L1. Overall length	mm	-	-	-	-	6 110	6 210	6 645*	6 465*
M1. Overall height of boom	mm	-	-	-	-	4 000	4 000	4 000*	3 970*
N. Front overhang	mm	-	-	-	-	2 930	3 030	3 465*	3 285*

*without bucket
**dipper arm for grab

Working Ranges & Digging

Monoblock boom 4,5 m and
dipper arm 2,0 m, 2,45 m, 3,1 m

Monoblock boom 4,5 m and
dipper arm for grab 3,0 m

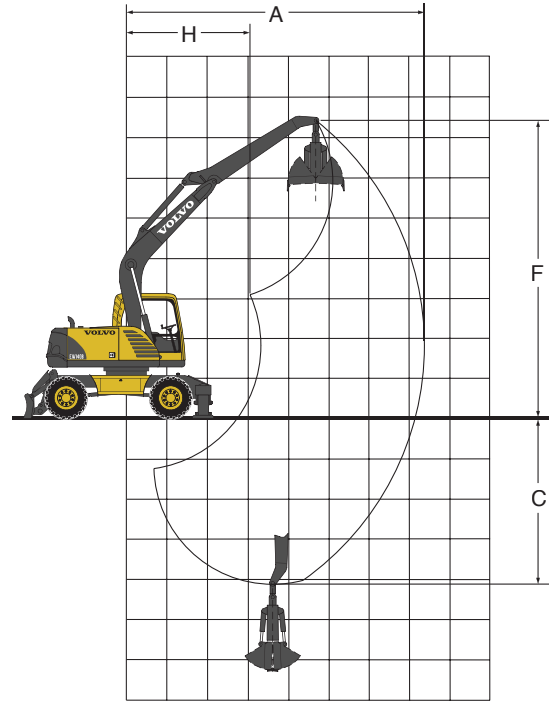
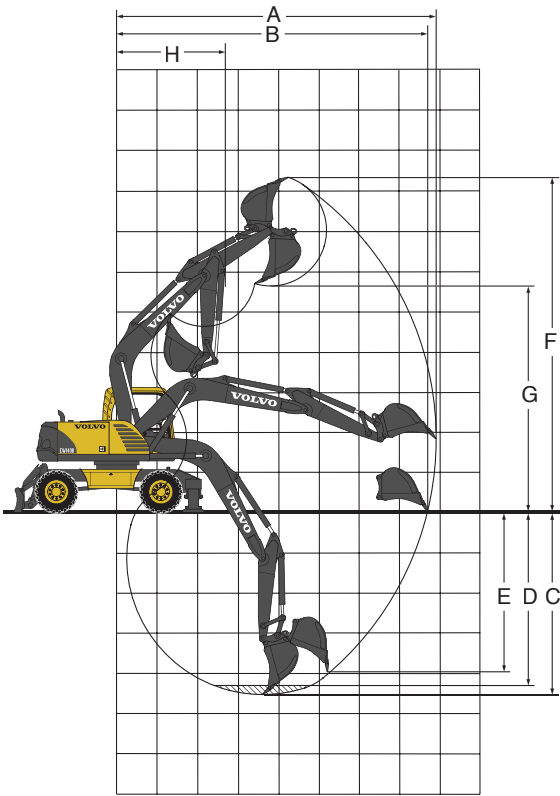

Monoblock boom	m	4,5	4,5	4,5	4,5
Dipper arm	m	2,0	2,45	3,1	3,0*
A. Max. digging reach	m	8,0	8,4	9,0	7,4
B. Max. digging reach at ground level	m	7,7	8,2	8,8	–
C. Max. digging depth	m	4,5	5,0	5,6	4,1
D. Max. digging depth (2440 mm level)	m	4,3	4,8	5,5	–
E. Max. vertical wall digging depth	m	4,0	4,4	4,9	–
F. Max. cutting height	m	8,3	8,6	8,9	7,4
G. Max. dumping height	m	5,7	5,9	6,3	–
H. Min. front slew radius	m	2,7	2,7	2,8	3,1

* Dipper arm for grab

Digging forces with direct fit bucket:					
Bucket radius	m	1,26	1,26	1,26	–
Breakout force (SAE/ISO)	kN	89,5 / 97,9	89,5 / 97,9	89,5 / 97,9	–
Tearout force (SAE/ISO)	kN	71,5 / 72,2	62,7 / 63,1	53,1 / 53,3	–
Rotation angle, bucket	°	185°	185°	185°	–

Max. permitted sizes for quickfit buckets:					
GP-bucket (1,5 t/m ³)	l	915	840	720	–
GP-bucket (1,8 t/m ³)	l	760	700	600	–

Max. permitted sizes for direct fit buckets:					
GP-bucket (1,5 t/m ³)	l	940	865	745	–
GP-bucket (1,8 t/m ³)	l	780	720	620	–

Note: 1. Bucket size based on SAE-J296, heaped material with a 1:1 angle of repose.
2. "Max permitted sizes" are for reference only and are not necessarily available from the factory.

Working Ranges & Digging Forces

2-piece boom 4,7 m and
dipper arm 2,0 m, 2,45 m, 3,1 m

2-piece boom 4,7 m and
dipper arm for grab 3,0 m

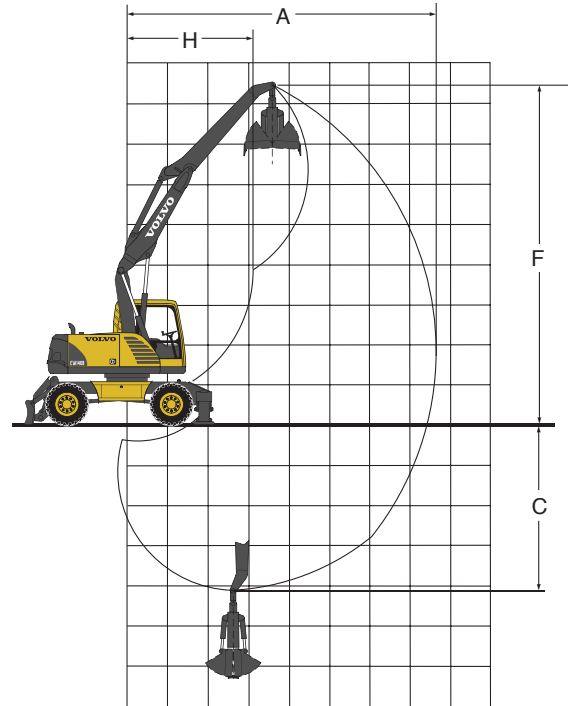
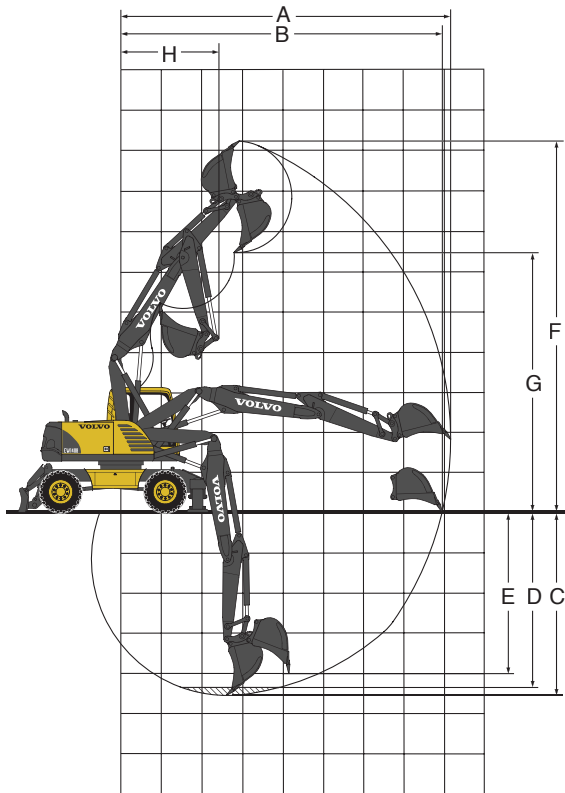

2-piece boom	m	4,7	4,7	4,7	4,7
Dipper arm	m	2,0	2,45	3,1	3,0*
A. Max. digging reach	m	8,2	8,6	9,3	7,7
B. Max. digging reach at ground level	m	8,0	8,4	9,1	-
C. Max. digging depth	m	4,6	5,0	5,7	4,1
D. Max. digging depth at (2440 mm level)	m	4,4	4,8	5,5	-
E. Max. vertical wall digging depth	m	3,1	3,5	4,1	-
F. Max. cutting height	m	9,2	9,6	9,9	8,4
G. Max. dumping height	m	6,5	6,8	7,3	-
H. Min. front slew radius	m	2,6	2,6	2,8	3,1

* Dipper arm for grab

Digging forces with direct fit bucket:					
Bucket radius	m	1,26	1,26	1,26	-
Breakout force (SAE/ISO)	kN	89,5 / 97,9	89,5 / 97,9	89,5 / 97,9	-
Tearout force (SAE/ISO)	kN	71,5 / 72,2	62,7 / 63,1	53,1 / 53,3	-
Rotation angle, bucket	°	185°	185°	185°	-

Max. permitted sizes for quickfit buckets:					
GP-bucket (1,5 t/m ³)	l	855	770	675	-
GP-bucket (1,8 t/m ³)	l	710	640	560	-



Max. permitted sizes for direct fit buckets:					
GP-bucket (1,5 t/m ³)	l	865	795	700	-
GP-bucket (1,8 t/m ³)	l	720	660	580	-

Note: 1. Bucket size based on SAE-J296, heaped material with a 1:1 angle of repose.
2. "Max permitted sizes" are for reference only and are not necessarily available from the factory.

Lifting Capacity

At the arm end, without bucket. Unit: 1 000 kg

For lifting capacity including bucket, simply subtract actual weight of bucket from the following values.

 Across under-carriage  Along under-carriage	Lifting hook related to ground level	Reach from machine centre																u = support up		d = support down										
		1,5 m		3,0 m		4,5 m		6,0 m		7,5 m		Max. reach				Max. m														
		u	d	u	d	u	d	u	d	u	d	u	d	u	d		u	d												
4,7 m 2-piece boom 3,0 m dipper arm for grab Front dozer blade Rear outriggers	6,0 m									2,4	3,5*	3,5*	3,5*					2,2	3,5*	3,5*	3,5*	6,4								
	4,5 m									2,4	3,6*	3,6*	3,6*					1,8	3,0	2,9	3,4*	7,2								
	3,0 m									3,4	4,8*	4,8*	4,8*	2,3	3,9*	3,8	4,0*	1,6	2,8	2,7	3,7*	1,6	2,7	2,6	3,4*	7,6				
	1,5 m									3,2	5,8*	5,6	5,9*	2,2	3,8	3,6	4,5*	1,6	2,7	2,6	3,8*	1,5	2,7	2,6	3,6*	7,7				
	0,0 m									3,0	5,6	5,4	6,5*	2,1	3,7	3,5	4,8*					1,6	2,7	2,6	3,9*	7,5				
	-1,5 m	4,5*	4,5*	4,5*	4,5*	5,2	8,9*	8,9*	8,9*	2,9	5,5	5,3	6,6*	2,0	3,6	3,5	4,8*					1,7	3,0	2,9	4,0*	6,9				
	-3,0 m	8,2*	8,2*	8,2*	8,2*	5,3	8,5*	8,5*	8,5*	3,0	5,6*	5,3	5,8*									2,1	3,8	3,6	4,0*	5,9				
-4,5 m					5,3*	5,3*	5,3*	5,3*													3,5*	3,5*	3,5*	3,5*	4,2					
4,7 m 2-piece boom 2,0 m dipper arm Rear dozer blade	7,5 m																								4,2*	4,2*	4,2*	4,2*	3,5	
	6,0 m									3,2	3,8	4,1*	4,1*												2,5	2,8	3,3*	3,3*	5,3	
	4,5 m					5,6*	5,6*	5,6*	5,6*	3,1	3,6	4,5*	4,5*	2,0	2,3	3,5	4,0*							1,8	2,1	3,0*	3,0*	6,2		
	3,0 m									2,9	3,4	5,3*	5,3*	1,9	2,2	3,5	4,3*							1,6	1,8	2,9*	3,0*	6,7		
	1,5 m									2,7	3,2	5,2	6,2*	1,8	2,1	3,4	4,6*							1,5	1,7	2,8*	3,2*	6,8		
	0,0 m					4,6*	4,9*	4,9*	4,9*	2,6	3,0	5,1	6,5*	1,7	2,0	3,3	4,7*							1,5	1,8	2,9	3,6*	6,6		
-1,5 m					4,7	5,7	8,7*	8,7*	2,6	3,0	5,1	6,0*											1,8	2,1	3,4	4,2*	5,9			
-3,0 m																														
4,7 m 2-piece boom 2,45 m dipper arm Rear dozer blade	7,5 m																									3,1*	3,1*	3,1*	3,1*	4,3
	6,0 m									3,3	3,6*	3,6*	3,6*												2,1	2,4*	2,6*	2,6*	5,9	
	4,5 m									3,2	3,7	4,0*	4,0*	2,0	2,3	3,6*	3,7*							1,6	1,9	2,4*	2,4*	6,7		
	3,0 m					5,4	6,4	7,5*	7,5*	2,9	3,4	5,0*	5,0*	1,9	2,2	3,5	4,0*							1,4	1,6	2,4*	2,4*	7,2		
	1,5 m									2,7	3,2	5,2	5,9*	1,8	2,1	3,4	4,4*							1,3	1,6	2,5*	2,5*	7,2		
	0,0 m					4,5	5,4*	5,4*	5,4*	2,5	3,0	5,0	6,4*	1,7	2,0	3,3	4,6*							1,4	1,6	2,6*	2,8*	7,0		
-1,5 m					4,5	5,5	9,2*	9,2*	2,5	3,0	5,0	6,2*	1,7	2,0	3,3	4,4*							1,5	1,8	3,0	3,4*	6,4			
-3,0 m																														
4,7 m 2-piece boom 3,1 m dipper arm Rear dozer blade	7,5 m									3,2*	3,2*	3,2*	3,2*													2,2*	2,2*	2,2*	2,2*	5,3
	6,0 m													2,1	2,4	3,0*	3,0*							1,7	1,9*	1,9*	1,9*	6,6		
	4,5 m									3,3*	3,4*	3,4*	3,4*	2,0	2,4	3,3*	3,3*							1,4	1,6	1,8*	1,8*	7,4		
	3,0 m					5,7	6,1*	6,1*	6,1*	3,0	3,5	4,4*	4,4*	1,9	2,3	3,5*	3,7*	1,3	1,5	2,5	2,7*			1,2	1,4	1,8*	1,8*	7,8		
	1,5 m					4,9	5,9	7,3*	7,3*	2,7	3,2	5,3*	5,5*	1,8	2,1	3,4	4,2*	1,3	1,5	2,4	3,2*			1,2	1,4	1,9*	1,9*	7,9		
	0,0 m					4,5	5,5*	5,8*	5,8*	2,5	3,0	5,0	6,2*	1,7	2,0	3,3	4,5*	1,2	1,4	2,3	2,9*			1,2	1,4	2,1*	2,1*	7,7		
	-1,5 m					4,4	5,4	8,1*	8,1*	2,4	2,9	4,9	6,3*	1,6	1,9	3,2	4,5*							1,3	1,6	2,4*	2,4*	7,1		
-3,0 m					4,5	5,5	8,4*	8,4*	2,5	2,9	5,0	5,6*	1,7	2,0	3,3	3,8*							1,7	2,0	3,2	3,7*	6,0			

Notes: 1. Working pressure with Power Boost = 36 MPa

2. The above values are in compliance with ISO standard 10 567. They do not exceed 87 % of hydraulic lifting capacity or 75 % of tipping load, with the machine on firm, level ground.

3. Load capacities marked with an asterisk (*) are limited by machine's hydraulic lifting capacity rather than tipping load.

STANDARD EQUIPMENT

Engine

Turbocharged air-to-air cooling,
4 stroke Volvo diesel engine with water cooling, electronically controlled direct injection that meets EU Step 2 emission requirements
Air intake heater
Electric engine shut-off
Fuel filter and water separator
Fuel filler pump: 50 l/min with automatic shut-off
Aluminium core radiator

Electric / Electronic control system

Contronics – computerized monitoring and diagnostic system
Master switch
Automatic idling system
One-touch power boost
Adjustable monitor
Engine restart prevention circuit
Safety stop/start function
High capacity halogen lamps
– Frame mounted 2
– Cab mounted 2
Alternator, 80 A
Batteries, 2 x 12 V / 140 Ah
Start motor, 24 V / 4,8 kW

Undercarriage

2-speed power transmission plus creep speed
Oscillating front axle $\pm 9^\circ$
2-circuit travel brakes
Maintenance-free propeller shafts

Superstructure

Counterweight, 2470 kg
Service walkway with anti-slip grating
Centralized lubricating point for slew bearing

Cab and interior

Heater
Hydraulic dampening cab mounts
Adjustable operator seat and joystick control console
Adjustable steering wheel
Flexible antenna
Hydraulic safety lock lever
Control joystick, with 5 switches each
Cab, all-weather sound suppressed, includes:
– Ashtray
– Cup holder
– Lighter
– Door locks
– Tinted glass

- Floor mat
- Horn
- Large storage area
- Pull-up type front window
- Removable lower windshield
- Seat belt
- Safety glass
- Windshield wiper with intermittent feature
- Radio assembly preparation
- Sun shield, front
- Anti-vandalism kit assembly preparation
- Master ignition key

Hydraulic system

Load sensing hydraulic system
Cylinder cushioning
Cylinder contamination seals
Return filter of full flow type 2000 h exchange interval
Pressure relief system (servo accumulator)
Thermostatically controlled cooling fan
Hose rupture valve for boom
Hydraulic oil, ISO VG46

Digging equipment

Attachment points for extra hydraulics
Centralized lubrication point

ALTERNATIVE EQUIPMENT

Undercarriage

Twin tyres 10.00–20
Single tyre 18R-19.5
Stone protection rings
Front dozer blade and rear outriggers
Rear dozer blade
4 outriggers
Grab holder

Digging equipment

Booms

4,5 m monoblock
4,7 m 2-piece boom
4,7 m monoblock offset boom

Dipper arms

2,0 m
2,45 m and 3,1 m
3,0 m dipper arm for grab

Buckets

General Purpose bucket (GP)

Capacity	Width
190 l	400 mm
260 l	500 mm
340 l	600 mm
420 l	700 mm
500 l	800 mm
580 l	900 mm
670 l	1 000 mm
750 l	1 100 mm

Cab and interior

Seat:
– Fabric seat
– Fabric seat, with heater
– Fabric seat, with heater and air suspension

OPTIONAL EQUIPMENT

(Standard in certain markets)

Engine

Diesel-powered cab and engine heater with digital timer
Electric engine heater, 220V/110V

Electric / Electronic control system

Travel alarm
Rotating warning beacon
Extra work lights:
– Service walkway 1 and counterweight 1
– Boom-mounted 2

Undercarriage

Mudguards, front / rear
Tool box, left hand side / right hand side
Rear axle with drum brake
Cruise control
Cruise control with adjustable creep speed

Cab and interior

Heater & air-conditioner, ECC
Falling object guard (FOG)
Cab mounted falling object protective structures (FOPS)
Rain shield, front
Sun shield, roof, rear
Sunlight protection, roof (steel)
Safety net for front window
Lower wiper
Stereo cassette radio
Anti-vandalism kit

Hydraulic system

Hose rupture valve for dipper arm
Float position on boom
Hydraulic oil, ISO VG 32
Hydraulic oil, ISO VG 68
Hydraulic oil, biodegradable 46

Hydraulic equipment for:

- A. Hammer/shears
- B. Slope bucket/rotator
- C. Grab/clam shell
- D. Quickfit

Hydraulic quickfit

S6

Attachments

Ripper, S6
Hammer holder, S6
Grab holder, S6

Service

Tool kit
Hand lamp, 24 V



Volvo Construction Equipment is different. It's designed, built and supported in a different way. That difference comes from an engineering heritage of over 170 years. A heritage of thinking first about the people who actually use the machines. About how to help them be safer, more comfortable, more productive. About the environment we all share. The result of that thinking is a growing range of machines and a global support network dedicated to helping you do more. People around the world are proud to use Volvo. And we're proud of what makes Volvo different – **More care. Built in.**



All products are not available in all markets. Under our policy of continuous improvement, we reserve the right to change specifications and designs without prior notice. The illustrations do not necessarily show the standard version of the machine.

VOLVO

Construction Equipment
www.volvo.com

Ref No. 21 3 433 1150 English
Printed in Sweden 2006.05-1,5 GMC
Volvo, Eskilstuna