

5.3 MAIN AND AUXILIARY (INCL. THIRD) WINCH BRAKE

CAUTION

- (1) Adjustment of Main and Auxiliary Winch Brakes
- (a) Set dimension (B) to 134.5 to 135mm (5.295 to 5.315inches) (adjusting with brake band upper adjusting nut © in Fig. 5-1).
 - (b) Set dimension (A) to 80 to 80.5mm (3.15 to 3.17 inches) [adjusting with item (12)] .

1. Be careful not to allow oil and grease to adhere to the lining surface of brake band (1).
2. Apply a thin coat of extreme pressure grease (Shell Albania EP-2 or equivalent) to pins (15 and 19) when assembling.

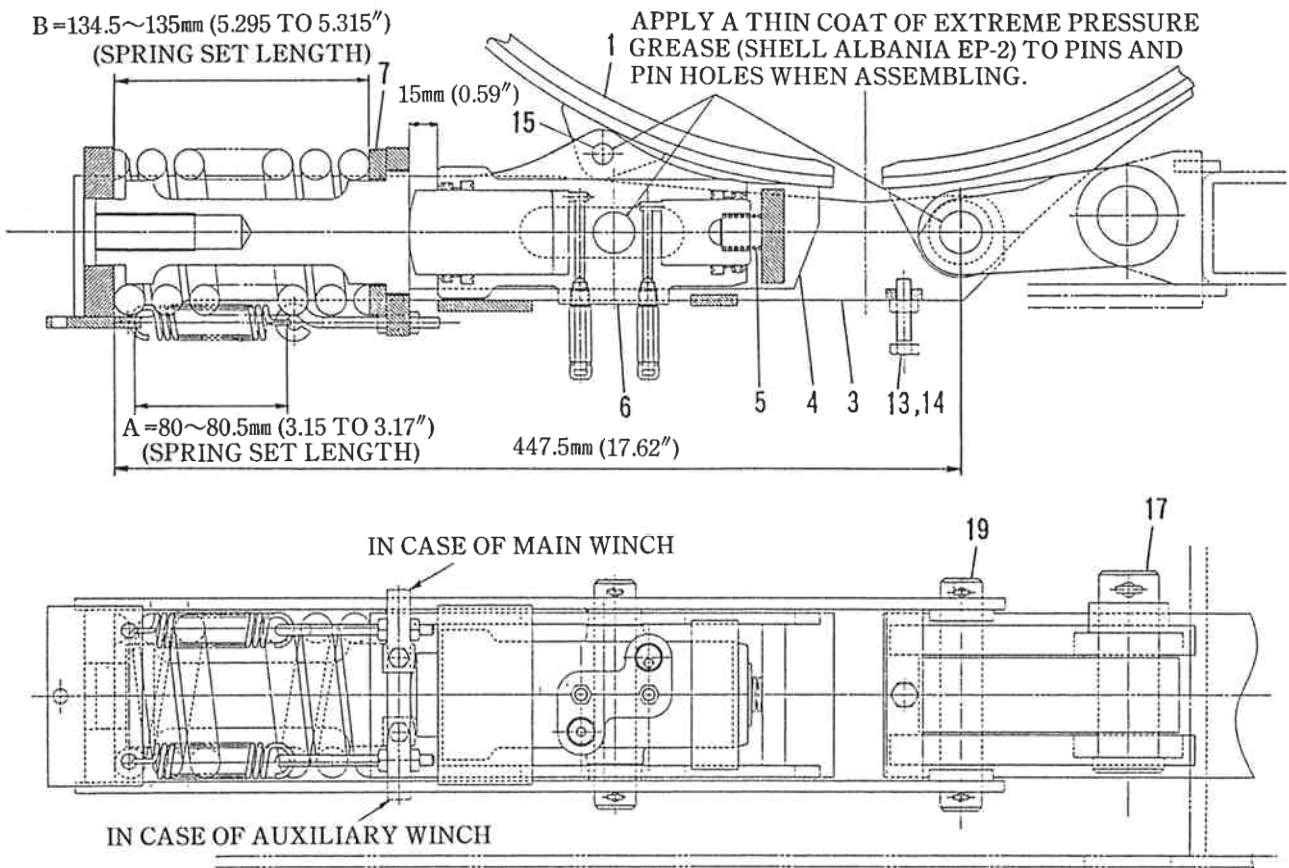

Fig. 5-9 Main and Auxiliary Brake Assembly

CAUTION

(2) Adjustment of Third Drum Brake

- (a) Set dimension (A) to 408.0mm (16.06in) by adjusting item (16).
- (b) Set dimension (E) to 30mm (1.181in) by adjusting item (30).
- (c) With the negative brake engaged, set dimension (C) to 35mm (1.378in). Adjust dimensions (C) with the brake band adjusting nut (see Fig. 5-2).
- (d) With the negative brake released, adjust dimension (C) to 29mm (1.142in) and stroke (F) to 6mm (0.236in).
- (e) After adjusting step (d), set dimension (B) to 82.7mm (3.256in) by adjusting item (16).

- 1. Be careful not to allow oil and grease to adhere to the lining surface of brake band (1).
- 2. Apply a thin coat of extreme pressure grease (Shell Albania EP-2 or equivalent) to pins (8, 17 and 19) when assembling.

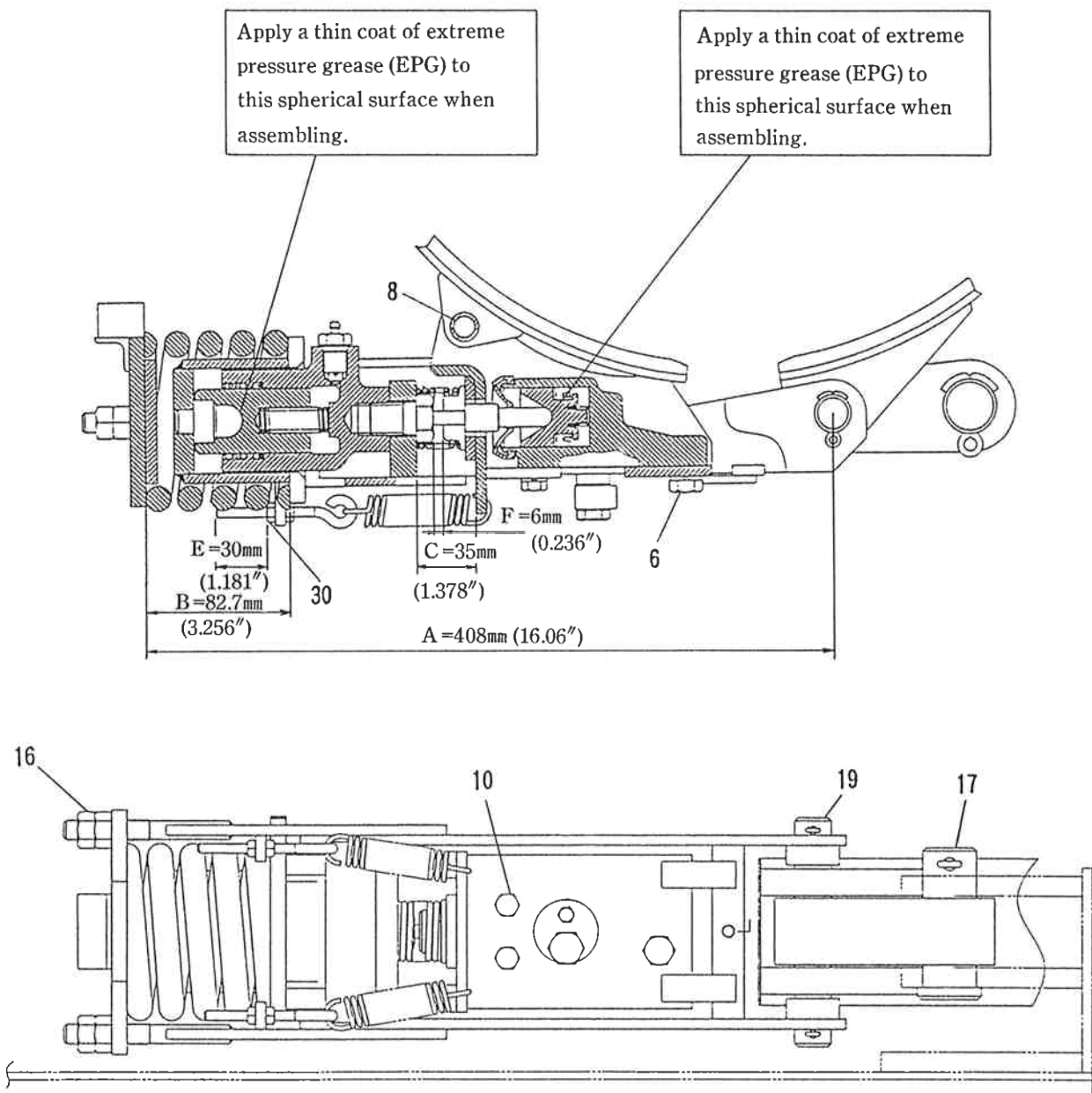

Fig. 5-10 Third Drum Brake Adjustment

5.4 MAIN AND AUXILIARY (INCL. THIRD) WINCH CLUTCHES

(1) Adjustment of Main and Auxiliary Winch Clutches

If the clearance between the clutch lining and the clutch drum is not proper, or if air exists in the clutch cylinder, the winch operation might be impossible. To adjust the winch clutch, proceed as follows :

- (a) Engage the winch drum lock.
- (b) Place the winch clutch lever in the FREE position.
- (c) Loosen lock nuts (1), loosen adjusting bolts (2, 3 and 4) so that the clutch band does not contact the head of the adjusting bolts.
- (d) Adjust dead end adjusting bolt (3) in the dead end of the clutch band so that the clearance between the drum and the clutch lining becomes approximately 0.6mm (0.024").
In the same way, adjust adjusting bolt (4) in the live end so that the clearance becomes approximately 1.0mm (0.04").
- (e) Turn push rod (5) so that wheel cylinder (6) is retracted completely when the clutch is released.

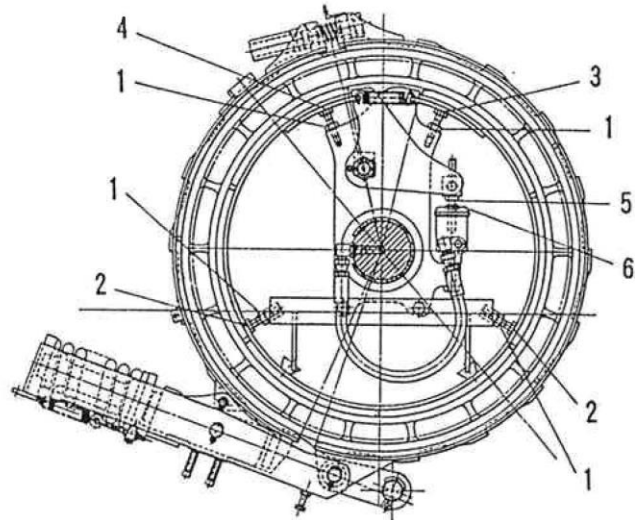

- | | |
|--------------------------------------|--------------------------------------|
| 1. LOCK NUT | 4. ADJUSTING BOLT
(LIVE END SIDE) |
| 2. ADJUSTING BOLT | 5. PUSH ROD |
| 3. ADJUSTING BOLT
(DEAD END SIDE) | 6. WHEEL CYLINDER |

MAIN WINCH CLUTCH : AS SHOWN IN THIS FIG.
AUXILIARY WINCH CLUTCH : OPPOSITE TO THIS FIG.

Fig. 5-11 Main and Auxiliary Winch Clutch Adjustment

NOTE

The piston in the wheel cylinder must return to the stroke end position in the cylinder whenever the clutch is disengaged.

- (f) Adjust two adjusting bolts (2) so that the clutch lining face does not contact the drum when the clutch is released. (Adjust the clearance to be approximately 0.6mm.)

NOTE

To raise the performance of the clutch, repeat the procedures of steps (d) to (f).

- (g) Pull the main winch clutch lever toward the operator to engage the clutch and check for performance.

After confirming that the performance is proper, tighten all lock nuts (1) firmly.

- (h) Release the drum lock.
- (i) Upon completion of adjustment, under the conditions of free fall, make sure that the hook can be lowered freely.

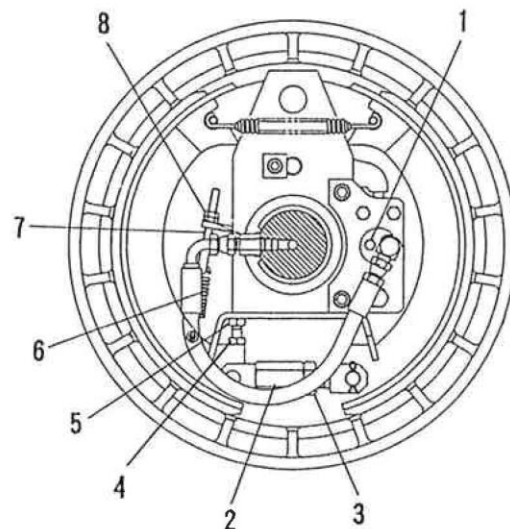

- | | |
|-------------------|-------------|
| 1. BLEEDER SCREW | 5. NUT |
| 2. ADJUSTING NUT | 6. SPRING |
| 3. LOCK NUT | 7. EYEBOLT |
| 4. ADJUSTING BOLT | 8. LOCK NUT |

Fig. 5-12 Third Drum Clutch Adjustment

Next, lift a weight which is sufficiently heavy (allowable maximum load per one rope), and confirm that the clutch is engaged surely without any slippage.

NOTE

It is necessary to adjust the clearance between the clutch lining and the clutch drum according to wear of the lining.

(2) Adjustment of Third Drum Winch Clutch

- (a) Lower the hook, and place it on the ground.
- (b) Place the clutch lever in the FREE position.
- (c) Loosen lock nut (5), turn adjusting bolt (4) so that the clearance between the clutch shoe and the bolt becomes 1.5mm to 3mm, (0.059" to 0.118"), and lock nut (5). This adjustment is necessary only when using a new clutch shoe or new linings.
- (d) Loosen lock nut (3), turn adjusting nut (2) so that the clutch shoe slightly clears the clutch drum and so that operating feeling is proper when operating the clutch lever, and secure lock nut (3).
- (e) With eyebolt (7) and nut (8), adjust the length of spring (6) so that engagement and disengagement are proper and so that the clutch lining does not contact the clutch drum during rotation when the clutch is released.
- (f) Upon completion of adjustment, lower the hook under the condition of free fall, and make sure that the hook can be lowered smoothly.
Next, lift a load, and confirm that the clutch is surely engaged without any slippage.
- (g) Tighten the all lock nuts securely.

NOTE

- 1. The piston in the wheel cylinder must return to the stroke end position in the cylinder whenever the clutch is disengaged.
- 2. Distance of the clutch shoes should be adjusted according to wear of the linings.

5.6 ADJUSTMENT OF FREE FALL INTERLOCK

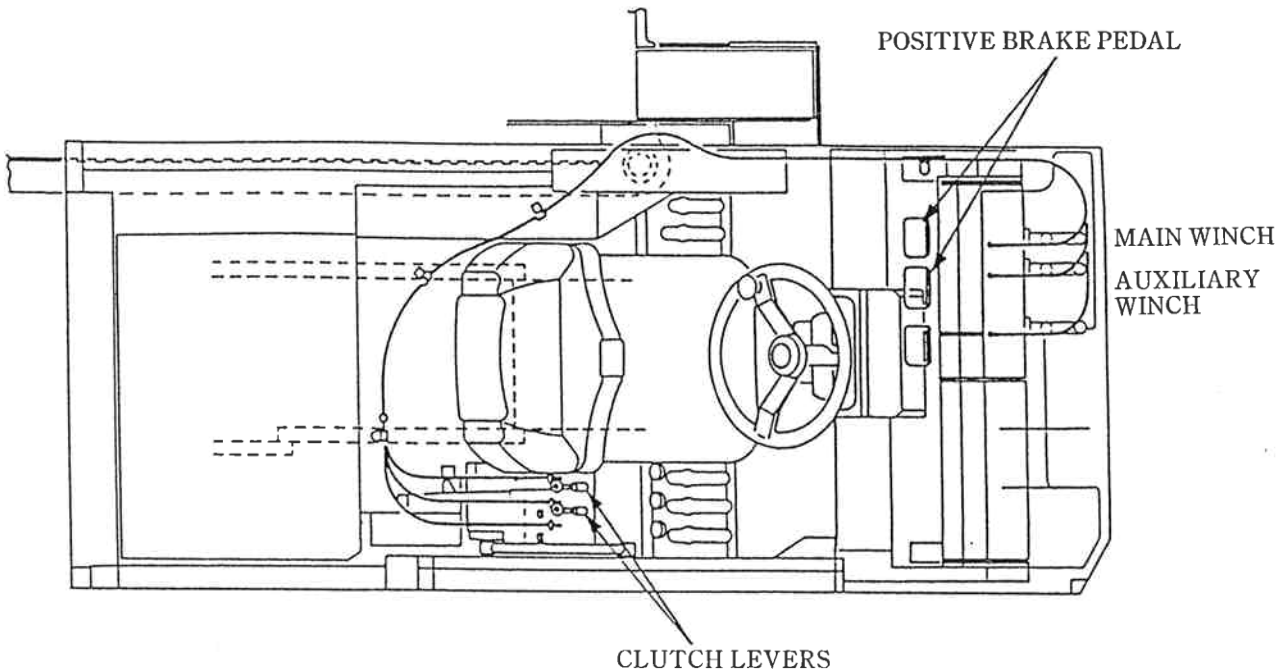

Fig. 5-15 Free Fall Interlock Device

(a) Normal condition

When stroke ① reaches 50 to 55mm (1.97 to 2.16 inches), interlock of the clutch lever is released and the clutch lever can be operated freely. This case is normal and adjustment is unnecessary.

(b) When adjustment is required.

After adjusting the master cylinder, adjust the cable lock nut so that point ② comes in contact with point ③ surely without depressing the pedal, and that the interlock is released when the pedal stroke is 50 to 55mm.

(c) After adjustment, make sure the pedal stroke by step (a)

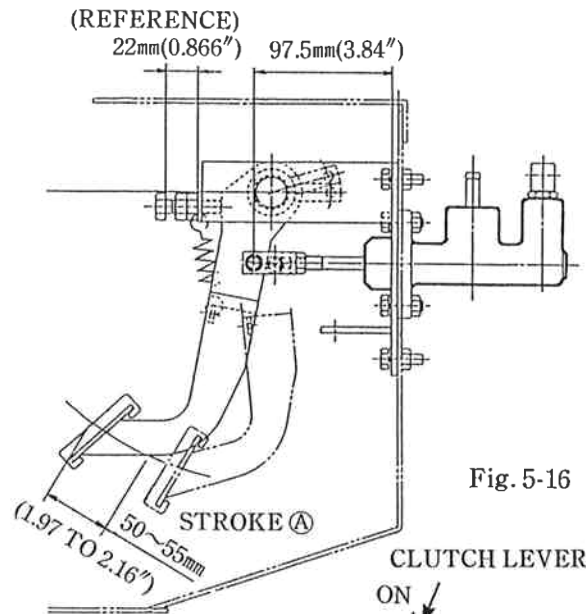

Fig. 5-16

ADJUST SO THAT INTERLOCK IS RELEASED FOR 50 TO 55mm OF PEDAL STROKE ①

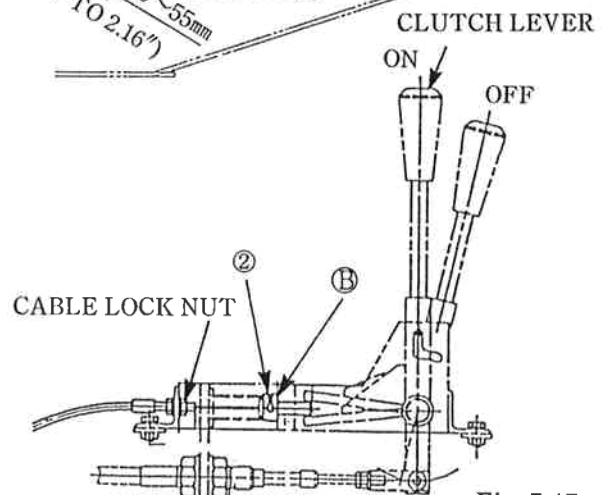
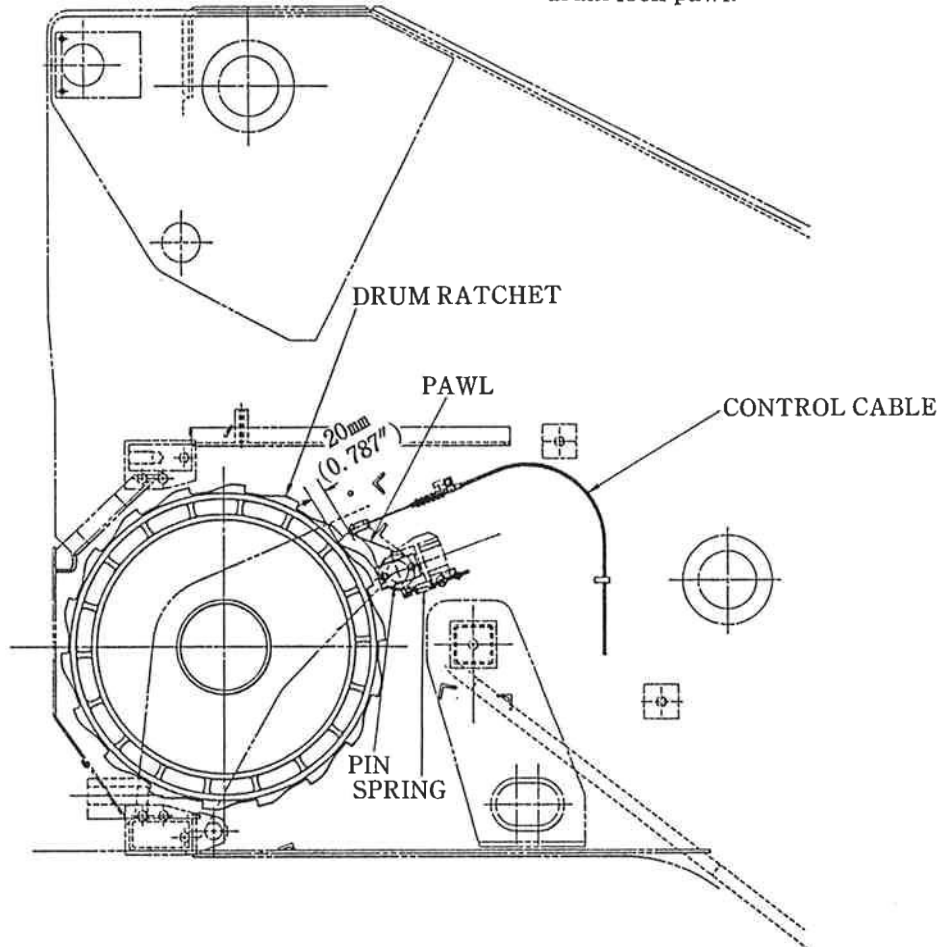

Fig. 5-17

(2) Adjusting the Drum Lock

To adjust the drum lock, proceed as follows :

- (a) With the drum lock ON, make sure the pawl is completely engaged with the bottom of the drum ratchet.
- (b) With the drum lock disengaged, adjust the adjusting bolt so that the clearance between the pawl and the top of the drum ratchet teeth is 10mm (0.394in), then tighten the lock nut securely.
- (c) Do not forget lubrication to the pin for the drum lock pawl.



MAIN WINCH DRUM LOCK : AS SHOWN IN THIS FIG.
AUXILIARY WINCH DRUM LOCK : OPPOSITE TO THIS FIG.

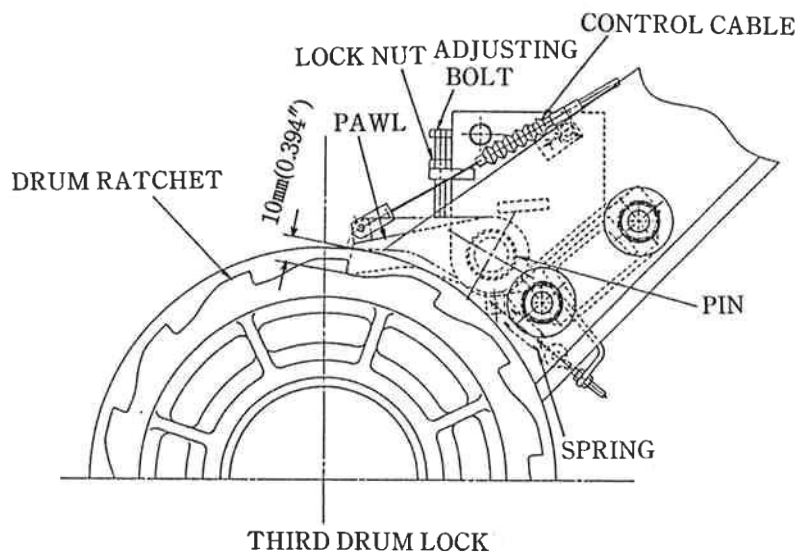

THIRD DRUM LOCK
Fig. 5-14 Adjustment of Drum Lock

DOWNLOAD

MANUAL

HERE

6 . TEST PROCEDURES AND MAINTENANCE STANDARDS

6.1 TEST PROCEDURES

(1) BRAKE

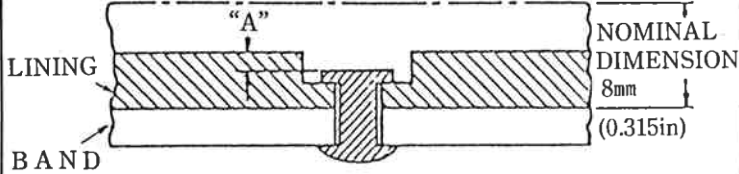
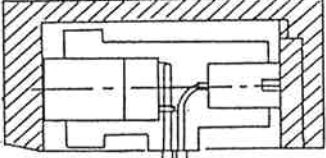
Test Procedure	Maintenance Standards
<p>1. Lining Wear Limit Measure "A" for minimum thickness.</p> 	<p>Replace lining when "A" is less than 1mm (0.04in).</p>
<p>2. Brake Cylinder Pressure Test Apply 250kg / cm² (3555psi) hydraulic pressure to brake cylinder for 5 seconds.</p> <p style="text-align: center;">NOTE Do not allow brake cylinder to reach its stroke end. Limit stroke before applying pressure as shown.</p>  <p style="text-align: center;">PRESSURE OF 250kg / cm² (3555psi)</p>	<p>Cylinder should be free from oil leakage and any other abnormal condition.</p>
<p>3. Check brake cylinder and piston for wear and scratches. Measure clearance between cylinder and piston.</p>	<p>Recommended clearance for replacement of those units is 0.13mm (0.005in).</p>
<p>4. Master Cylinder Pressure Test Apply 250kg / cm² (3555psi) hydraulic pressure to master cylinder for 5 seconds.</p>	<p>Cylinder should be free from oil leakage and any other abnormal condition.</p>
<p>5. Time Required for Cylinder Piston Returning Fill cylinder with brake fluid at normal temperature. Check time for piston to return when delivery port is closed with piston full extended.</p>	<p>Within 1 second.</p>
<p>6. Check for wear and scratches on master cylinder and piston. Measure clearance between cylinder and piston.</p>	<p>Recommended clearance for replacement of those units is 0.2mm (0.008in)</p>