

Fig 46.

- 22** Install Bonfig tool 6689969020 on the end cover (6) and using lifting tackle place the end cover (6) on the gearbox housing (13).



Fig 47.

- 23** Tighten the 20 M12 x 35 socket head screws (1), with a torque wrench to 130 Nm.



Fig 48.

- 24** Insert the M22 x 1,5 plugs (3) and the washers (2) into the oil draing-filling holes of the end cover (6). Tighten the plugs with a torque wrench to 60-70 Nm.

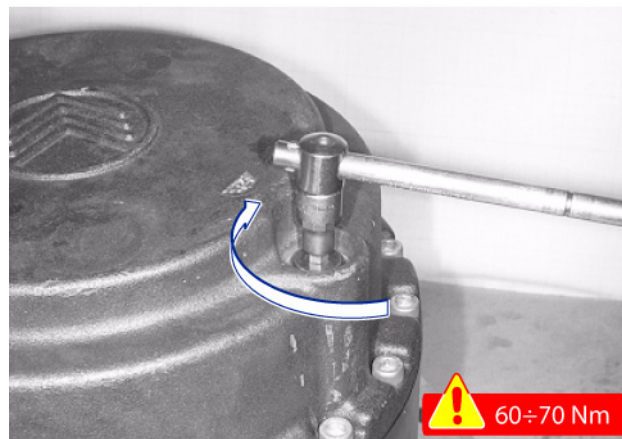

Fig 49.

- 25** Use pliers to assemble the circlip (20) into its seat in the coupling (19).



Fig 50.

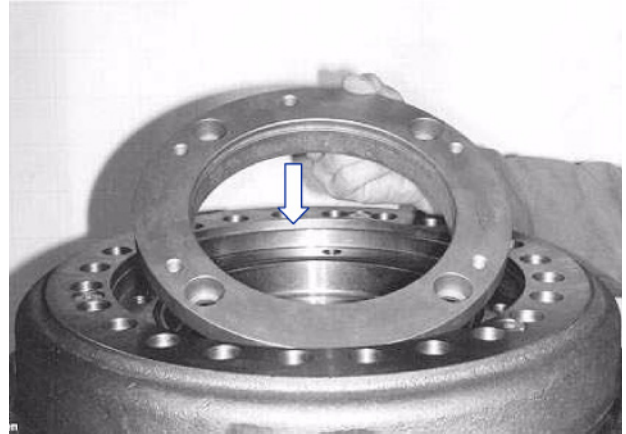

Fig 52.

26 Insert the coupling (19).

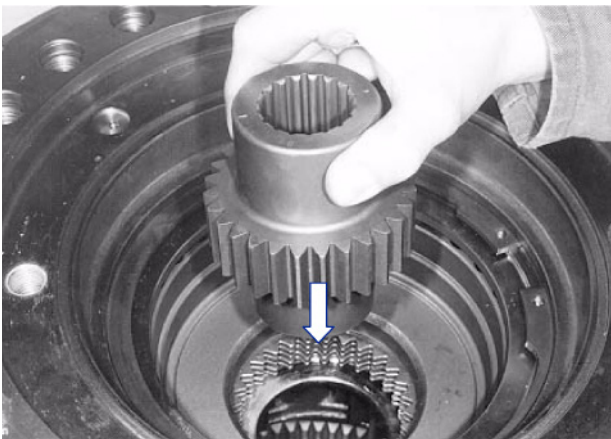

Fig 51.

27 Insert the motor adaptor flange (17).

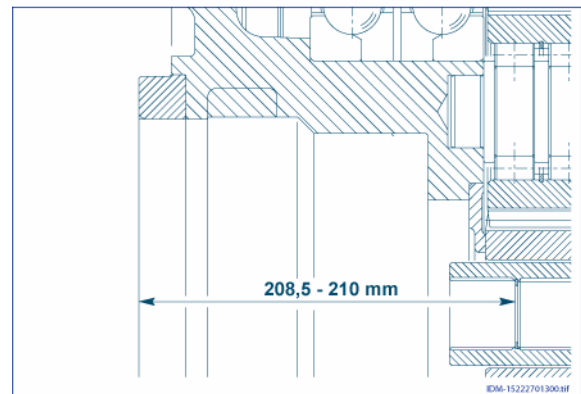

Fig 53.

Note: Before assembling the hydraulic motor, verify by a depth slide gauge the correct assembly of the unit checking the axial distance as shown.

28 Assemble the O-ring seal (18) into its seat in the hydraulic motor.

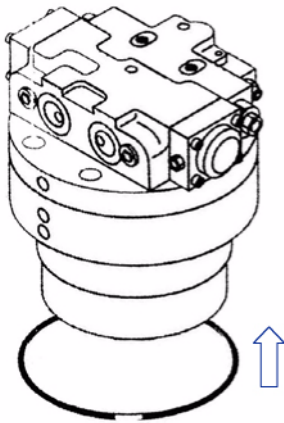

Fig 54.

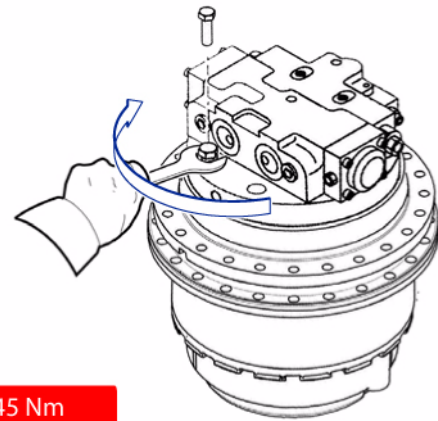

Fig 56.

- 29 Use an M12 eyebolt tightened into the motor base plate to assemble the hydraulic motor (21).

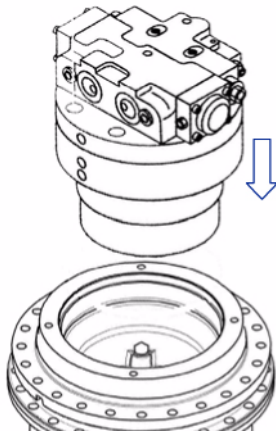

Fig 55.

- 30 Tighten the 4 M12 x 120 socket head screws (22) to 145 Nm.