

Document Title: Clutch discs 1st-2nd, changing in machine	Function Group: 421	Information Type: Service Information	Date: 2014/5/23
Profile:			

Clutch discs 1st-2nd, changing in machine

Op nbr 42176

E 1693 Pressing tool

Kukko 18-2 Puller

Bolt 1/2" UNC, length 75 mm, 2 pcs

Bolt 1/2" UNC, length 38 mm, 4 pcs

1. Remove the thick oil pipe between transmission and oil pump.
Take care of the oil which runs out.
2. Remove cover and drive gear/shaft for the tachometer sensor, see Fig.

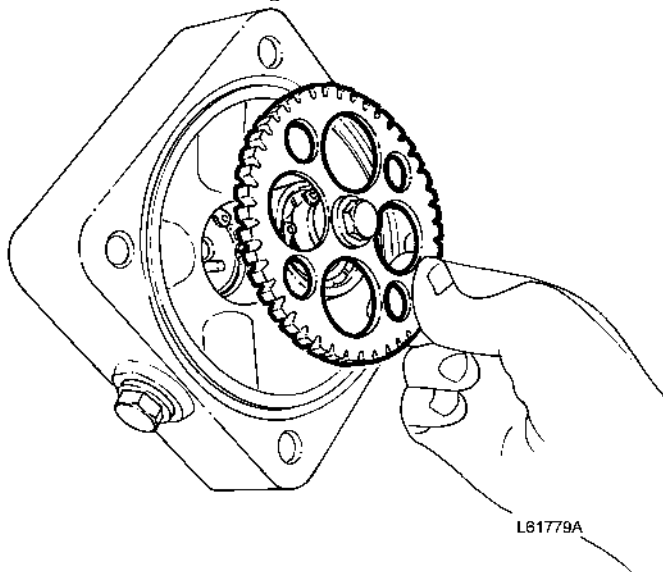

Figure 1
Removing/fitting drive gear

Detach the cable harness from the sensor.

3. Remove the cover over the 1st and 2nd clutches.
4. Press in the thrust plate according to Fig. and remove lock ring and thrust plate.

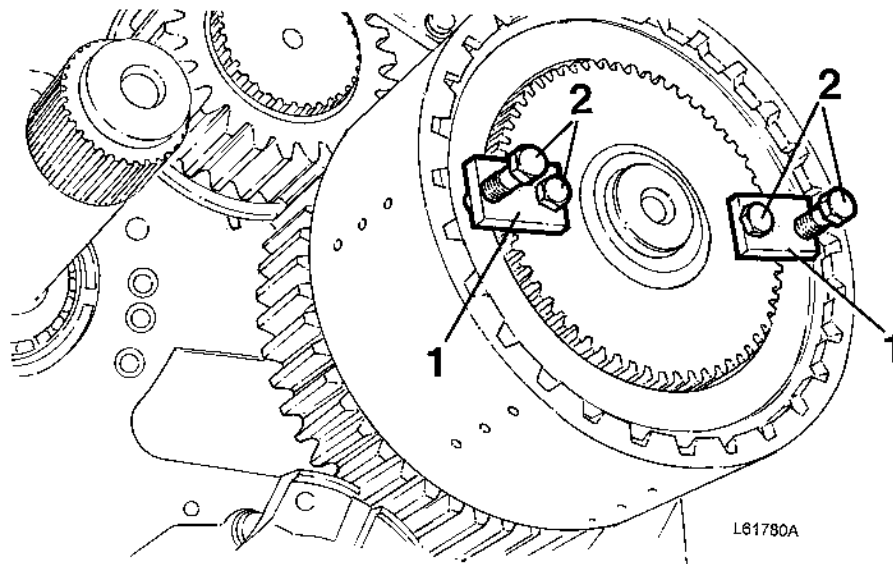

Figure 2
Pressing disc pack

1. E 1693
2. Bolt 1/2" UNC

5. Remove the lock ring from the end of the shaft and pull away the disc hub. See Fig.

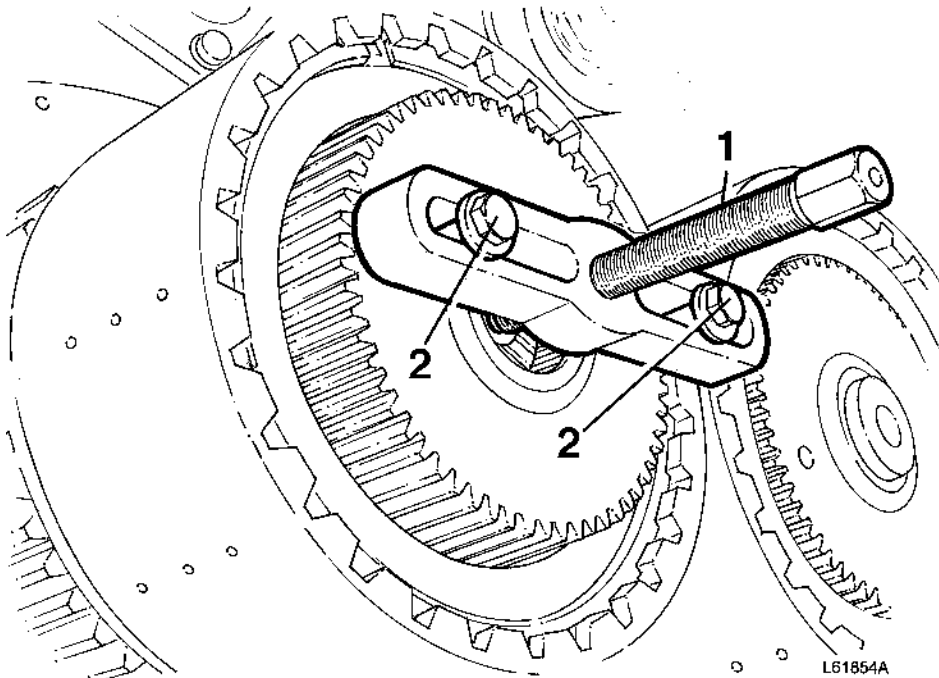

Figure 3
Removing disc hub

1. Kukko 18-2
2. Bolt 1/2" UNC, length 75 mm (3 in)

6. Remove springs, guide pins and discs.
7. Remove the piston with the aid of two 3/8" UNC bolts.
8. Check the clutch drum bearings. See "Clutch drum bearings, changing". [Invalid linktarget]
9. Change expanding ring and oil seal in the clutch drum, see Fig.

**Thank you very much
for reading.**

PLEASE CLICK HERE.

Then back to the site.

At the bottom of the

page,

free add to card.

Then get more free